

Aerospect SP-150DT Specification

General

Post Height:	508 mm (20 in) optional 635 mm, 762 mm (25 in, 30 in)
Arm Length:	457 mm (18 in)
Granite:	762 mm x 508 mm x 152mm thick (30 in X 20 in X 6 in thick)
Worktable Height:	1016 mm (40 in)
Machine Weight:	720 lb (327 kg)

Air Bearing

Load Capacity:	150 lb (68 kg)
Radial / Axial:	0.125 μ m (5 μ in)
Tilt Error Motion (coning):	< 0.025 μ m/mm (< 1 μ in/in)

Tilt & Center

Tilt Adjustment:	+/- 1°
Center Adjustment:	+/-3 mm (0.125 in)
Axis of Tilt:	51mm (2 in) above worktable
Work Table Diameter:	200 mm (8 in) optional 250 mm, 300 mm (10.6 in, 12 in)

Gage Heads (4- Std, 8- optional)*

Cartridge Style:	0.375 in OD, +/- 1 mm (0.040 in) travel
Lever Style:	+/- 0.30mm (+/-0.012 in) travel
Ultra Small:	+/- 0.25 mm (+/- 0.010 in) travel
Measurement resolution:	0.25 μ m (10 μ in)

SPS-150DT

150 lbs capacity. Perfect for small turbine components and assemblies.

Optimize your high speed engine stacks.



Electrical

Encoder:	1000 line
Flat screen LCD Display	
Industrial Computer	
CE Approved	
Printer included	
Power:	120VAC-50/60hz or 220 VAC-50/60hz
Power Consumption:	500VA
Air Requirements:	Pressure: 50 – 80 psig
Air Usage:	1.0 scfm @ 60 psig, (28 l/min)

*Note: Other Gage heads available upon request

Floor Plan

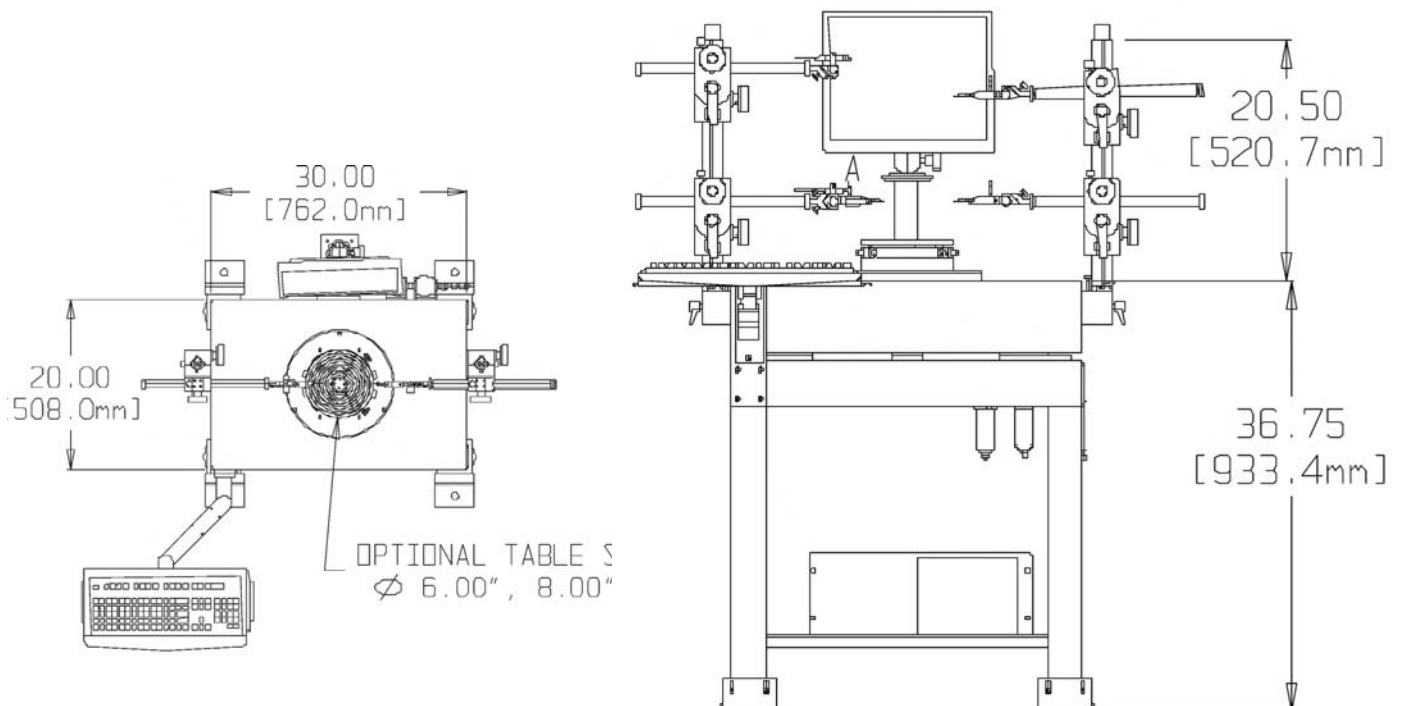

NOTE: AMETEK Precitech pursues a policy of continual improvement due to technical developments. We therefore reserve the right to deviate from catalog specifications.

Serving a global market

Taylor Hobson is world renowned as a manufacturer of precision measuring instruments used for inspection in research and production facilities. Our equipment performs at nanometric levels of resolution and accuracy.

To complement our precision manufacturing capability we also offer a host of metrology support services to provide our customers with complete solutions to their measuring needs and total confidence in their results.

Contracted Services from Taylor Hobson

- Inspection services**
 measurement of your production parts by skilled technicians using industry leading instruments in accord with ISO standards
- Metrology training**
 practical, hands-on training courses for roundness and surface finish conducted by experienced metrologists
- Operator training**
 on-site instruction will lead to greater proficiency and higher productivity
- UKAS Calibration and Testing**
 certification for artifacts or instruments in our laboratory or at customer's site

For the above services, contact our Center of Excellence:

email: taylor-hobson.cofe@ametec.com
 or call: +44 116 276 3779

- Design engineering**
 special purpose, dedicated metrology systems for demanding applications
- Precision manufacturing**
 contract machining services for high precision applications and industries
- Preventative maintenance**
 protect your metrology investment with a Talycare service cover plan

For the above services, contact our Sales Department:

email: taylor-hobson.sales@ametec.com
 or call: +44 116 246 3034



0026



TAYLOR HOBSON
A8248 ISO9001

Taylor Hobson France

Rond Point de l'Epine Champs
 Batiment D, 78990 Elancourt, France
 Tel: +33 130 68 89 30 Fax: +33 130 68 89 39
taylor-hobson.france@ametec.com



Taylor Hobson Germany

Postfach 4827, Kreuzberger Ring 6
 65205 Wiesbaden, Germany
 Tel: +49 611 973040 Fax: +49 611 97304600
taylor-hobson.germany@ametec.com



Taylor Hobson Italy

Via De Barzi
 20087 Robecco sul Naviglio, Milan, Italy
 Tel: +39 02 946 93406 Fax: +39 02 946 93450
taylor-hobson.italy@ametec.com



Taylor Hobson Japan

Sankyo Meguro Building 4-5-37,
 Kamiosaki, Shinagawa-Ku, Tokyo 141-0021, Japan
 Tel: +81 33494 5110 Fax: +81 33494 5119
taylor-hobson.japan@ametec.com



Taylor Hobson Korea

Hungkuk Life Building, 5th Floor 6-7, Soonae Dong
 Pundang-Ku, Seongnam, Kyungki-Do, 463-020, Korea
 Tel: +82 31 713 1371 Fax: +82 31 713 1372
taylor-hobson.korea@ametec.com



Taylor Hobson China Beijing Office

Room 2305, CITIC Building #19
 Jianguomenwai Dajie, Beijing, 100004, China
 Tel: +00 86 10 8526 2111 Fax: +00 86 10 8526 2141
taylor-hobson.beijing@ametec.com



Taylor Hobson China Shanghai Office

Part A, 1st Floor, Waigaoqiao Free Trade Zone
 Shanghai, 200131, China
 Tel: +00 86 21 58685111-110 Fax: +00 86 21 58680969-110
taylor-hobson.shanghai@ametec.com



Taylor Hobson Singapore

AMETEK Singapore, 10 Ang Mo Kio Street 65
 No. 05-12 Techpoint, Singapore 569059
 Tel: +65 6484 2388 Ext 120
taylor-hobson.singapore@ametec.com



Taylor Hobson USA

1725 Western Drive
 West Chicago, Illinois 60185, USA
 Tel: +1 630 621 3099 Fax: +1 630 231 1739
taylor-hobson.usa@ametec.com



Taylor Hobson UK

(Global Headquarters)
 PO Box 36, 2 New Star Road
 Leicester, LE4 9JQ, England
 Tel: +44 116 276 3771 Fax: +44 116 246 0579
 email: taylor-hobson.uk@ametec.com

